



Nano Scan Technology

Transportniy Drive 6, Dolgoprudniy, 141700, RU

web: www.nanoscantech.ru

E-Mail: info@nanoscantech.ru

Tel: +7 (495) 642 40 68,

Nano Scan Technology

Nano Innovations

Narrow Line width NSTL lasers



APPLICATIONS

Industry Metrology	Biomedical investigations	Optical Research
Holography	Opto acoustics	Cold atoms and molecules
Interferometry	Photo acoustics	Lithography
Lidar	Optical genetics	Nano photonics
Spectroscopy	Microdessection	Quantum electronics
Raman Spectroscopy	Maldi-TOF	Single molecule detection
Velocity Laser measurement	Flow cytometry	Dynamic light scattering
Semiconductor control	DNA sequencing	Fluorescence microscopy

Principles of operation

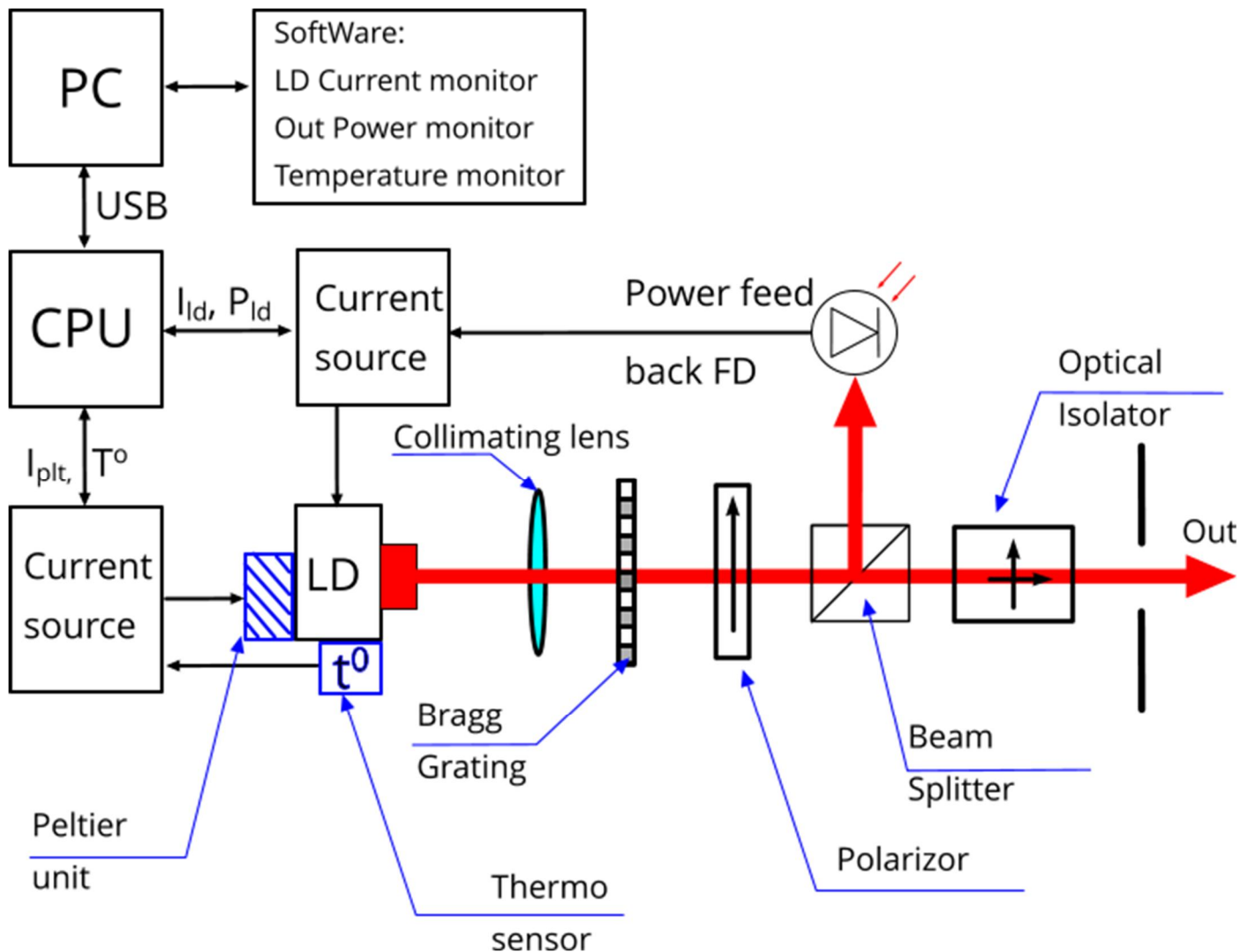

The device is a single-frequency laser with digital control of the radiation power and temperature of the laser diode. The power of the laser diode is controlled through a digital feedback system using a microcontroller and a controlled current source, as well as a feedback photodiode, which receives part of the optical radiation through a splitting prism. The temperature of the laser diode is controlled via a peltier element, a temperature sensor, a controlled current source and a microcontroller. Thus, digital feedback is also used to control the temperature. The device contains a number of optical elements for filtering and polarizing laser radiation. The laser beam from the diode passes through a collimation lens, a Bragg grating, which provides high-quality properties of single-mode and narrow line width, a polarizer, a splitting prism to ensure constant power feedback, and an optical isolator that prevents reflected laser radiation from entering the feedback system. The laser is controlled via a PC via a USB interface. Using the installed software, the desired power and temperature of the laser diode are set, as well as monitored in real time.

Software and electrical connections

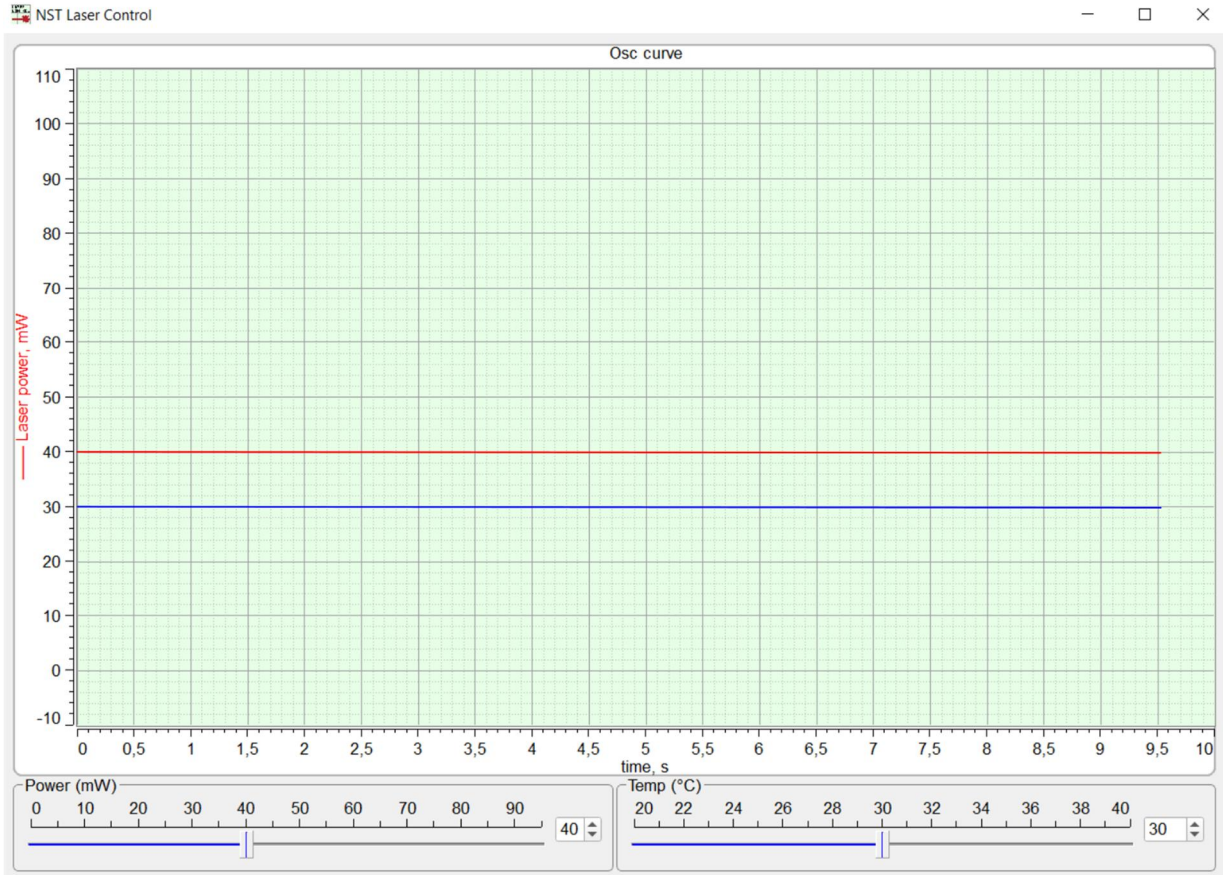

Features:

1. Power supply +5 V, 3A
2. USB 2.0/3.0
3. Software Win7/Win10/Linux
4. Constant current mode
5. Constant power mode
6. Software Current control
7. Software Power control
8. Software temperature control

Available models

Laser Model	WL λ , nm	Line width $\Delta \lambda$, pm	P, mW	Polarization	Beam size, mm
NSTL ALPHA	785	0.02	100	100:1 linear	0.25 x 0.7
NSTL DELTA	633	0.03	50	100:1 linear	0.6 x 0.9
NSTL BETTA	533	0.1	50	100:1 linear	0.7 x 0.9
NSTL GAMMA	405	0.1	20	100:1 linear	0.8 x 0.4

Mechanical Drawing

